



Stoginiai ventilatoriai

Roof fans

Dachventilatoren

Крышные вентиляторы



Stoginiai ventilatoriai, naudojami oro ištraukimui iš patalpos. Sparnuotė uždengta tinklo grotelėmis, apsaugančiomis ją nuo pašalinių daiktų, galinčių patekti iš aplinkos ir pažeisti sparnuotę mechaniškai. Nenaudojami užteršto oro, agresyvių, sprogių dujų transportavimui.

Sparnuotė: atgal lenktais sparneliais, cinkuoto plieno.

Variklis: išorinis rotorius, tiesioginė pavara, integruota termokontaktinė variklio apsauga, ilgai tarnaujantys nereikalaujantys priežiūros guoliai.

Korpusas: iš cinkuotos skardos.



Dachventilatoren, sie werden für Abluft aus dem Raum verwendet. Laufrad ist mit Netzgrill abgedeckt, der es vor Gegenständen schützt, die aus der Umgebung gelangen und Laufrad mechanisch beschädigen können. Nicht geeignet für die Beförderung von verschmutzter Luft, aggressiven, explosiven Gasen.

Laufrad ist rückwärts gekrümmt, aus verzinktem Stahl.

Der Motor: Außenrotor, Direktantrieb, integrierter Thermokontakt-Motorschutz, dauerhafte, keine Pflege erfordernde Lager.

Das Gehäuse: aus verzinktem Blech.



Roof fans with vertical discharge are used to extract air from different premises. Motorised impeller is protected with a meshwork grill which offers protection against external objects that could cause mechanical damage to the impeller. Not suitable for polluted air, aggressive and explosive gases.

Impeller with backward curved blades made of galvanized steel.

Motor: external rotor, motor protection built-in thermal-contact, free-maintenance ball bearings.

Housing: made of galvanized steel.



Крышные вентиляторы для вытяжки воздуха из помещений. Крыльчатка закрыта сетчатой решёткой, защищающей её от попадающих извне посторонних предметов, способных механически повредить крыльчатку. Не используются при транспортировке загрязнённого воздуха, агрессивных, взрывоопасных газов.

Крыльчатка: загнутые назад лопатки, оцинкованная сталь.

Двигатель: наружный ротор, прямая передача, встроенные термоконтакты двигателя, не требующие ухода подшипники с длительным сроком службы.

Корпус: оцинкованной жести.

Accessories

 KS
p. 196

 KSP
p. 195

 FSV
p. 201

 LSV
p. 197

 ATS
p. 182

 TGRV
p. 153

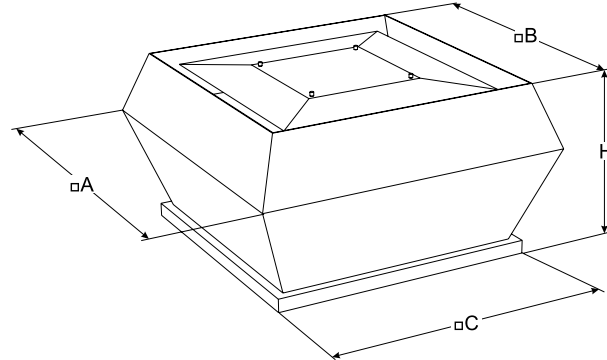

Type	Dimensions [mm]			
	A	B	C	H
VSV 250-2 L1	406	326	335	253
VSV 250-2S L1	420	319	335	298
VSV 311	560	470	435	330
VSV 355	720	618	595	400
VSV 400	720	618	595	435
VSV 450	900	748	665	475
VSV 500	900	748	665	495
VSV 560	1150	1010	939	590
VSV 630	1150	1010	944	626
VSV 710	1350	1176	1035	717

Accessories



TGRT
p. 154



MTY
p. 156

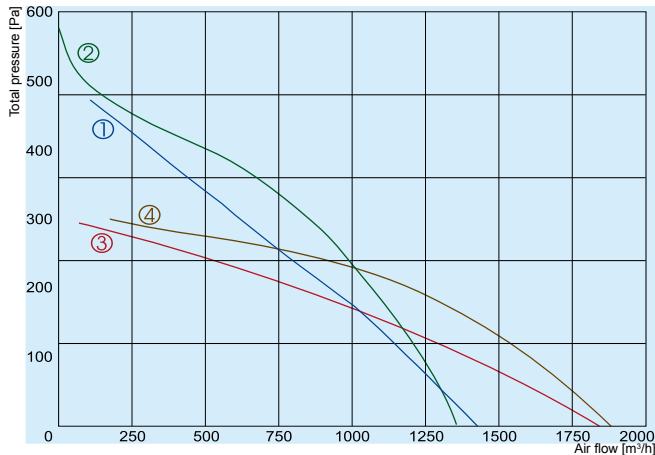

- ① VSV 250-2 L1
- ② VSV 250-2S L1
- ③ VSV 311-4 L1
- ④ VSV 311-4 L3

		250-2 L1	250-2S L1	311-4 L1	311-4 L3
Voltage/Frequency	[V/Hz]	230/50	230/50	230/50	400/50
Power consumption	[kW]	0,23	0,185	0,17	0,15
Current	[A]	0,89	0,81	0,90	0,36
Speed	[min ⁻¹]	2631	2650	1300	1400
Max. airflow	[m ³ /h]	1428	1350	1840	1880
Max. air temperature	[°C]	50	50	50	70
Total sound power level at 1 m	[dBA]	75	68	65	66
Total sound pressure level at 4/10 m	[dBA]	47/39	45/37	42/34	43/35
Speed controller		TGRV 1,5/MTY 1	TGRV 1,5/MTY 1	TGRV 1,5/MTY 1	TGRT 1
Weight	[kg]	8,3	8,1	18	18
Wiring diagram		No. 4	No. 3	No. 1	No. 2
Protection class:	motor	IP-44	IP-44	IP-44	IP-54
	terminal box	IP-54	IP-54	IP-54	IP-54

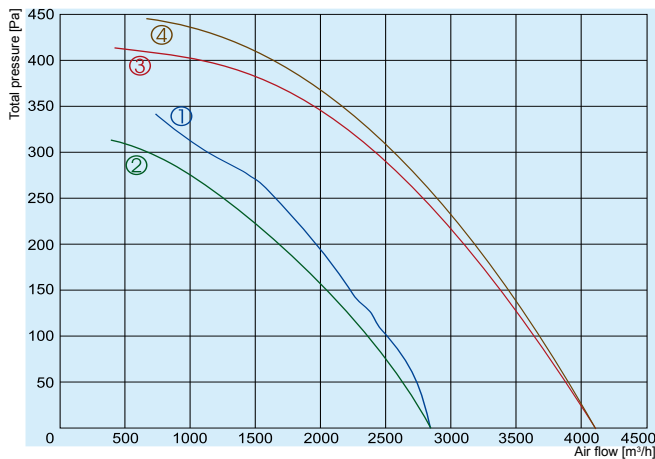

- ① VSV 355-4 L1
- ② VSV 355-4 L3
- ③ VSV 400-4 L1
- ④ VSV 400-4 L3

		355-4 L1	355-4 L3	400-4 L1	400-4 L3
Voltage/Frequency	[V/Hz]	230/50	400/50	230/50	400/50
Power consumption	[kW]	0,31	0,27	0,52	0,46
Current	[A]	1,35	0,47	2,20	0,85
Speed	[min ⁻¹]	1370	1310	1360	1340
Max. airflow	[m ³ /h]	2850	2850	4100	4100
Max. air temperature	[°C]	65	60	40	55
Total sound power level at 1 m	[dBA]	71	70	70	70
Total sound pressure level at 4/10 m	[dBA]	48/40	47/39	47/39	47/39
Speed controller		TGRV 1,5/MTY 2	TGRT 1	TGRV 3/MTY 4	TGRT 1
Weight	[kg]	28,4	28,4	32	32
Wiring diagram		No. 1	No. 2	No. 1	No. 2
Protection class:	motor	IP-54	IP-54	IP-54	IP-54
	terminal box	IP-54	IP-54	IP-54	IP-54

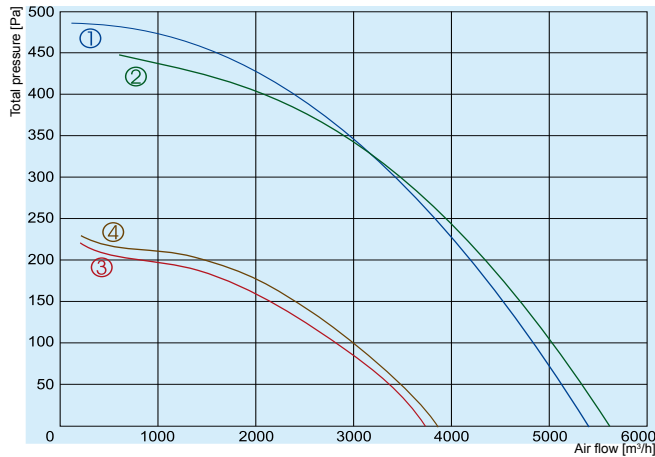

- ① — VSV 450-4 L1
- ② — VSV 450-4 L3
- ③ — VSV 450-6 L1
- ④ — VSV 450-6 L3

		450-4 L1	450-4 L3	450-6 L1	450-6 L3
Voltage/Frequency	[V/Hz]	230/50	400/50	230/50	400/50
Power consumption	[kW]	0,74	0,69	0,24	0,26
Current	[A]	3,20	1,30	1,05	0,63
Speed	[min ⁻¹]	1280	1230	840	870
Max. airflow	[m ³ /h]	5400	5600	3750	3900
Max. air temperature	[°C]	60	40	60	60
Total sound power level at 1 m	[dBA]	76	76	67	60
Total sound pressure level at 4/10 m	[dBA]	53/45	53/45	44/36	37/29
Speed controller		TGRV 4	TGRT 2	TGRV 2	TGRT 1
Weight	[kg]	47,6	49,4	47,1	47,1
Wiring diagram		No. 1	No. 2	No. 1	No. 2
Protection class:	motor	IP-54	IP-54	IP-54	IP-54
	terminal box	IP-54	IP-54	IP-54	IP-54

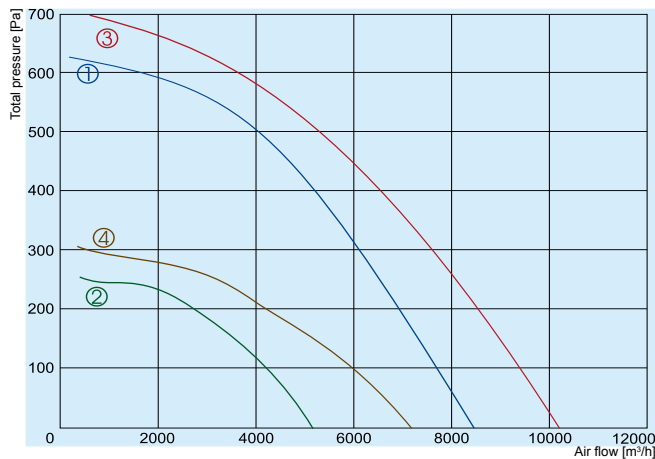

- ① — VSV 500-4 L3
- ② — VSV 500-6 L3
- ③ — VSV 560-4 L3
- ④ — VSV 560-6 L3

		500-4 L3	500-6 L3	560-4 L3	560-6 L3
Voltage/Frequency	[V/Hz]	400/50	400/50	400/50	400/50
Power consumption	[kW]	1,25	0,39	1,80	0,61
Current	[A]	2,30	0,81	3,40	1,05
Speed	[min ⁻¹]	1340	850	1230	830
Max. airflow	[m ³ /h]	8400	5150	10200	7550
Max. air temperature	[°C]	45	45	40	40
Total sound power level at 1 m	[dBA]	78	66	79	68
Total sound pressure level at 4/10 m	[dBA]	55/47	43/35	56/48	45/37
Speed controller		TGRT 3	TGRT 1	TGRT 4	TGRT 2
Weight	[kg]	56	50	128	119,5
Wiring diagram		No. 2	No. 2	No. 2	No. 2
Protection class:	motor	IP-54	IP-54	IP-54	IP-54
	terminal box	IP-54	IP-54	IP-54	IP-54

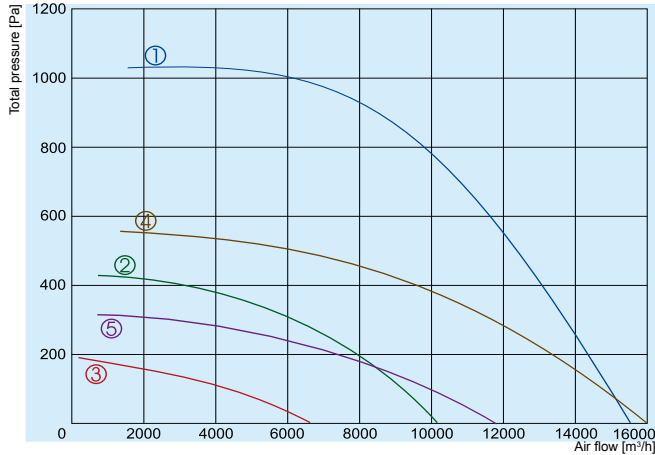

- ① VSV 630-4 L3
- ② VSV 630-6 L3
- ③ VSV 630-8 L3
- ④ VSV 710-6 L3
- ⑤ VSV 710-8 L3

		630-4 L3	630-6 L3	630-8 L3	710-6 L3	710-8 L3
Voltage/Frequency	[V/Hz]	400/50	400/50	400/50	400/50	400/50
Power consumption	[kW]	4,1	1,05	0,38	2,0	0,96
Current	[A]	6,80	2,2	0,88	4,0	1,9
Speed	[min ⁻¹]	1380	870	530	890	650
Max. airflow	[m ³ /h]	15600	10120	6620	16000	11900
Max. air temperature	[°C]	40	70	60	40	40
Total sound power level at 1 m	[dBA]	86	85	64	78	70
Total sound pressure level at 4/10 m	[dBA]	63/55	62/54	41/33	55/47	47/39
Speed controller		TGRT 7	TGRT 3	TGRT 1	TGRT 5	TGRT 2
Weight	[kg]	140	124	108	156	132
Wiring diagram		No. 2	No. 2	No. 2	No. 2	No. 2
Protection class:	motor	IP-54	IP-54	IP-54	IP-54	IP-54
	terminal box	IP-54	IP-54	IP-54	IP-54	IP-54

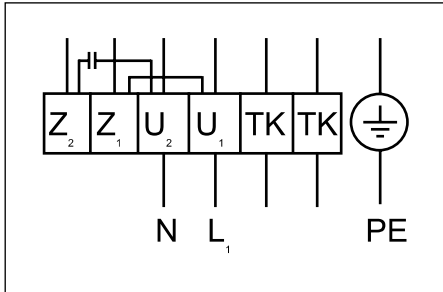
Wiring diagram No. 1 (1~230V)

U₁ - brown / braun
U₂ - blue / blau
Z₁ - black / schwarz
Z₂ - orange / orange
TK - white / weiß
PE - yellow-black / gelb-schwarz

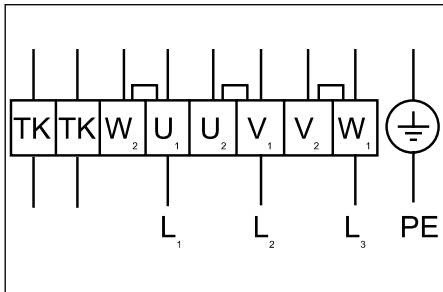
Wiring diagram No. 2 (Δ - 3~230V)

U₁ - brown / braun
V₁ - blue / blau
W₁ - black / schwarz
U₂ - red / rot
V₂ - gray / grau
W₂ - orange / orange
TK - white / weiß

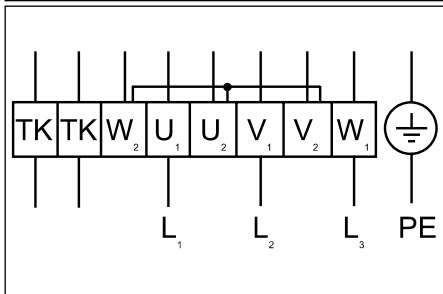
Wiring diagram No. 2 (Y - 3~400V)

U₁ - brown / braun
V₁ - blue / blau
W₁ - black / schwarz
U₂ - red / rot
V₂ - gray / grau
W₂ - orange / orange
TK - white / weiß

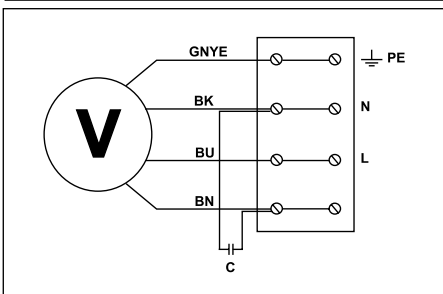
Wiring diagram No. 3 (1~230V)

GNYE - green-yellow
BK - black
BU - blue
BN - brown

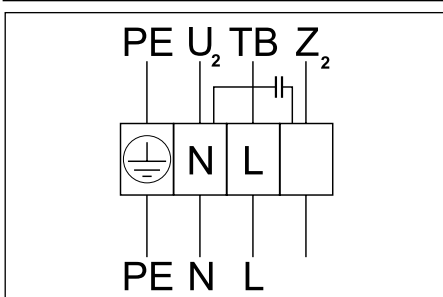
Wiring diagram No. 4 (1~230V)

U₂ - blue or grey
Z₂ - black
TB - braun